

THANK YOU FOR DOWNLOADING THIS MANUAL. I HOPE IT HELPS YOU RESOLVE ANY ISSUES YOU HAVE HAD WITH YOUR GAME.

THIS MANUAL WAS PURCHASED, AND SCANNED BY BASEMENT ARCADE ASSOCIATES, WWW.BASEMENTARCADE.COM AND IS OFFERED FOR FREE DOWNLOAD AT OUR SITE.

THIS PDF IS NOT TO BE DISTRIBUTED ON ANY COLLECTION CD / DVD, NOR IS TO BE LINKED TO VIA ANY OTHER INTERNET SITE WITHOUT PERMISSION FROM US. LIKEWISE IT IS NOT TO BE DISTRIBUTED FROM ANY OTHER SITE WITHOUT OUR PERMISSION.

ABIDING BY THESE REQUESTS, WILL INSURE THE CONTINUING SUPPORT OF NEW MANUALS ADDED TO OUR SITE.

ALL ORIGINAL COPYRIGHTS HELD BY THEIR ORIGINAL OWNERS, THIS PDF COPYRIGHTED BASEMENT ARCADE ASSOCIATES.

==MARK==

*PlayChoice-10*TM

OPERATION MANUAL

MODEL NO: PCH1-UP

MODEL NO: PCH1-UP-US

Nintendo[®]

Revision 1

—WARNING—

This equipment generates, uses, and can radiate radio frequency energy and if not installed and used in accordance with the instructions manual, may cause interference to radio communications. It has been tested and found to comply with the limits for a Class A computing device pursuant to Subpart J of Part 15 of FCC Rules, which are designed to provide reasonable protection against such interference when operated in a commercial environment. Operation of this equipment in a residential area is likely to cause interference in which case the user at his own expense will be required to take whatever measures may be required to correct the interference.

—WARNING—

Use of non-Nintendo parts or modifications of your Nintendo game circuitry may adversely affect the safety of your game, and may cause injury to your players.

www.basementarcade.com

Contents

1. Location Setup	1
A. Game Inspection	1
B. Game Installation	2
(1) Voltage Selection	3
(2) Power On/Off Switch	4
(3) Grounding of Game	4
(4) Adjustment of Video Monitor	5
2. Option Switch Settings	7
A. Game Settings	8
3. Self-Test and Bookkeeping	9
4. Maintenance and Repair	10
A. Fuse Replacement	10
B. Cleaning	10
C. Operation Panel	10
D. Video Monitor Removal	12
E. Game PCB Removal and ROM PBC Exchange	14
5. Radio Frequency Interference	14
6. Wiring and Connection	15
7. Parts Lists	17
A. PCH1-UP Game Cabinet Assembly	17
B. PCH1-UP Operation Panel Assembly	21
C. PCH1-UP Wiring Harnesses	22
D. PCH1-CPU PCB Assembly	23
E. PCH1-ROM PCB Assembly	25
F. 054-FCC PCB Assembly	25
G. 079-FCC PCB Assembly	26
H. PP-1000A Power Supply Assembly	26
I. PCH1-UP Fuses	27

1. Location Setup

A. Game Inspection

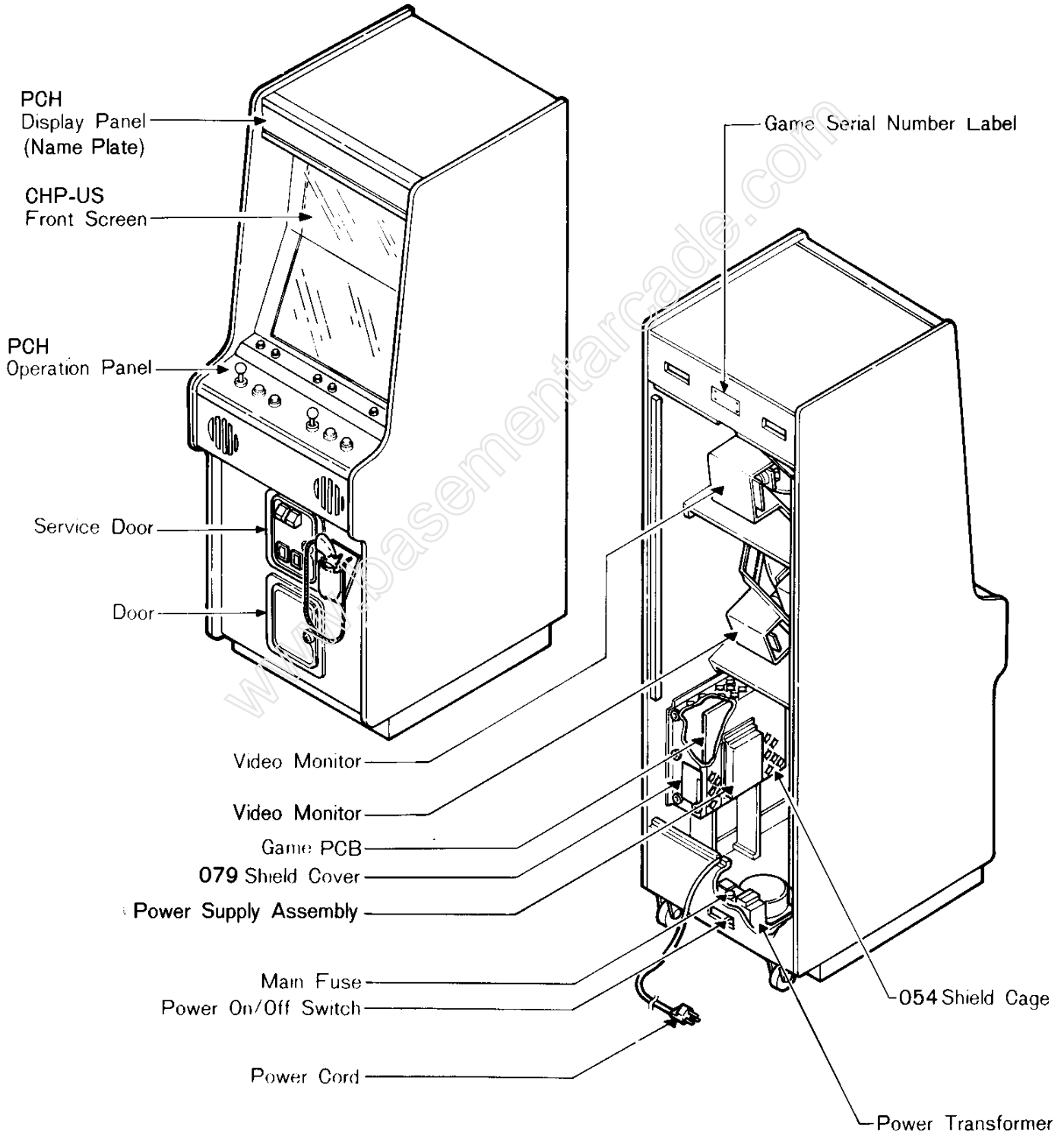

Fig. 1 Game Overview

WARNING

Check before plugging the game in !

The game "PlayChoice-10™" is shipped ready for operation, but a last visual check should be made to insure the final touch of quality control. Please check the following to help us insure that your new game was delivered to you in good condition.

- (1) Check the exterior of the game for shipping damage, dents, chips, or broken parts.
- (2) Remove the screws on the Rear Door Panel.
- (3) Unlock and open the Rear Door Panel, as well as the Service Door inspect the interior of the game as follows:
 - (a) Check that Plug-in connectors are firmly connected.
 - (b) Check that Plug-in integrated circuits on the Game PCB are firmly connected in their sockets.
 - (c) Check that all major subassemblies such as the Power Supply, Operation Panel, and Video Monitor are properly mounted.
 - (d) Remove the tie-wrap that holds the coiled Power Cord on the inside cabinet wall. Check the cord for any cuts or dents in the insulation.

B. Game Installation

Fig. 2 Installation Requirements

Power	:	170 watts
Temperature	:	0 to 38 deg.C (32 to 100 deg.F)
Humidity	:	Not over 95% relative
Space required	:	63 (W) × 90 (D)cm (24 3/4 × 35 1/2 in.)
Height	:	189 cm (74 1/2 in.)

(1) Voltage Selection

Before plugging in your game, make sure the Terminal Block of the Power Transformer is correct for your location's line voltage.

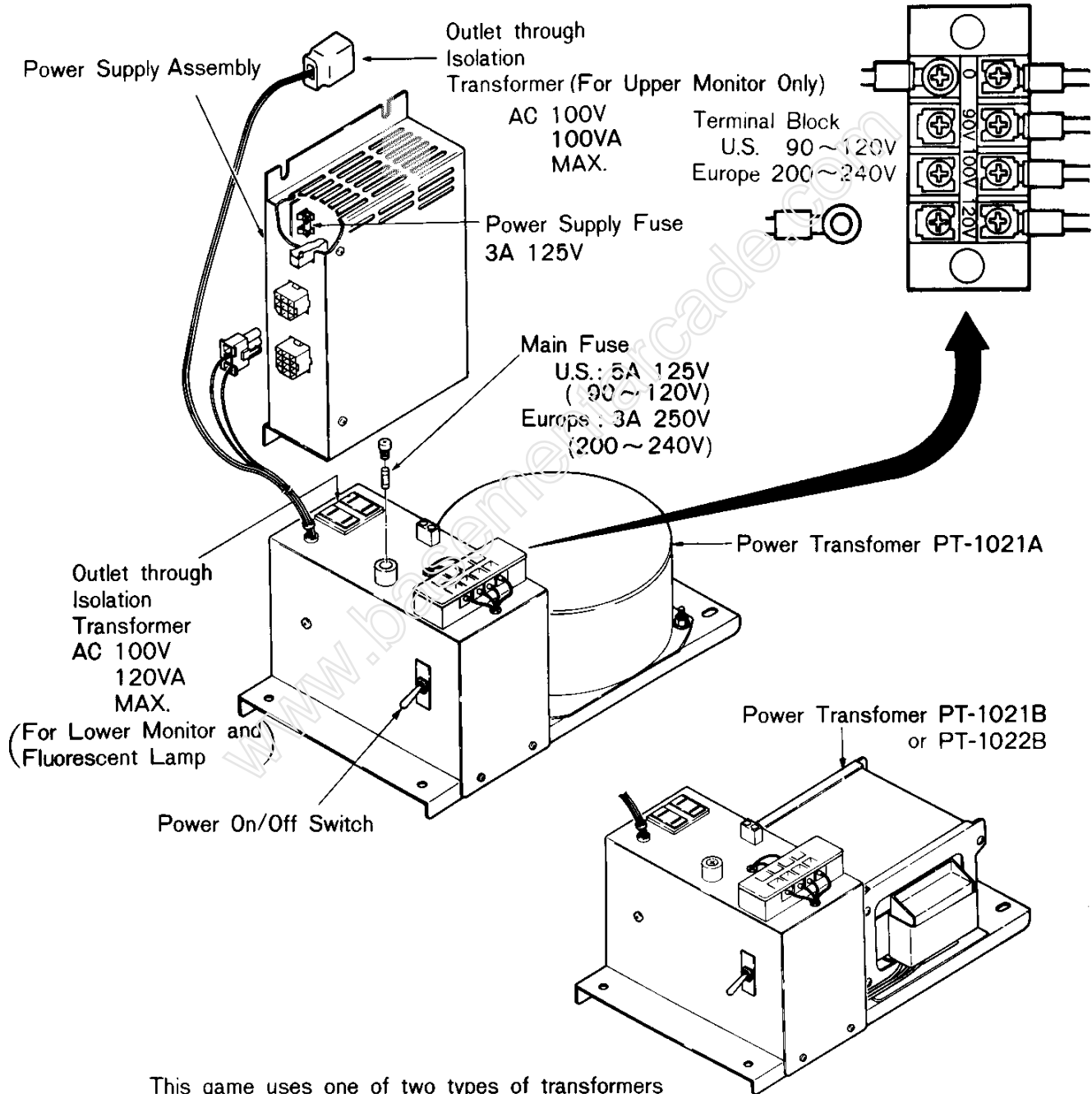

This game uses one of two types of transformers which are different in appearance but identical in function. The two types can be interchanged.

Fig. 3 Power Supply Assembly, Power Transformer and Voltage Selection

(2) Power On/Off Switch

A Power On/Off Switch is located in the rear of the game at the bottom center of the cabinet. See Fig. 1.

If the results of the preceding steps are satisfactory, you are ready to plug the game in, and set the Power On/Off Switch to the "On" position.

WARNING

This game **MUST** be grounded. Failure to do so may result in destruction of electronic components.

(3) Grounding of Game (Use only if 3 wire outlet is unavailable.)
See Fig. 4

- (a) A grounding wire should be connected to a grounding bar or a metal pipe which is firmly inserted into the ground.
- (b) Do not connect the grounding to a water pipe, because polyvinyl-chloride pipes are sometimes used in water lines, and the electronic continuity to the ground may be interrupted.
- (c) Absolutely do not connect the grounding wire to a gas pipe, as this can be extremely dangerous.

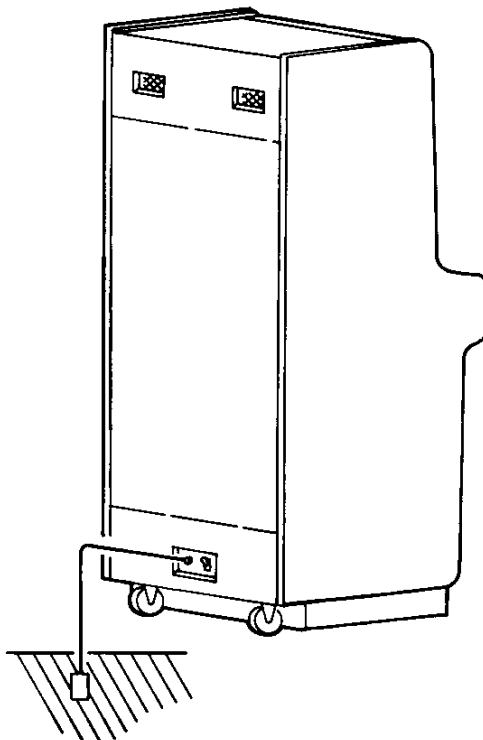

Fig. 4 Grounding of Game

(4) Adjustment of Video Monitor

This game uses one of four types of Video Monitors which are different in appearance but identical in function. The four types can be interchanged.

- (a) Video Monitor : [32 Type] 20-EZV(R-C)
- (b) Video Monitor : [33 Type] 20-EZV(R-C)
- (c) Video Monitor : [35 Type] 20-Z2AW

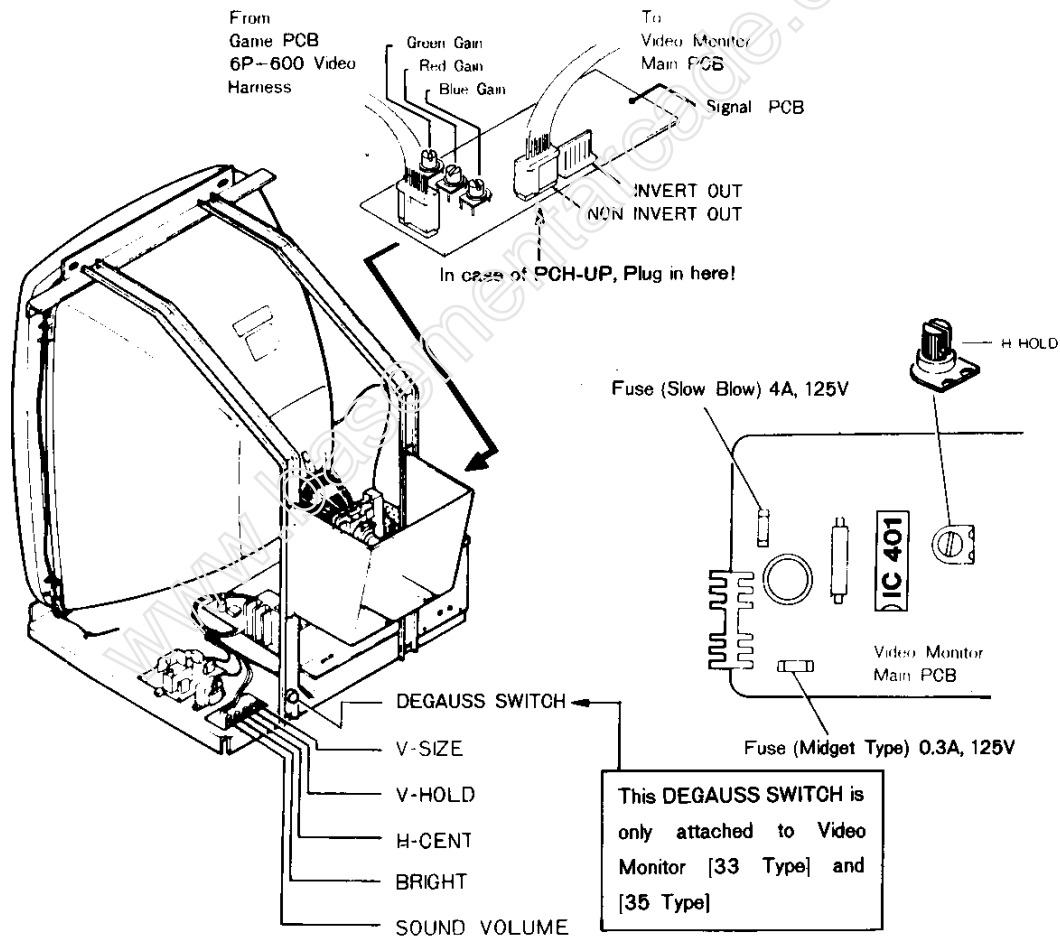

Fig. 5 Video Monitor : [32 Type] 20-EZV(R-C)
 [33 Type] 20-EZV(R-C)
 [35 Type] 20-Z2AW

—WARNING—

Do not touch the inside of the Video Monitor.
 It contains many parts supplied with high voltage.

(d) Video Monitor : [Y51 Type] XM-2001N

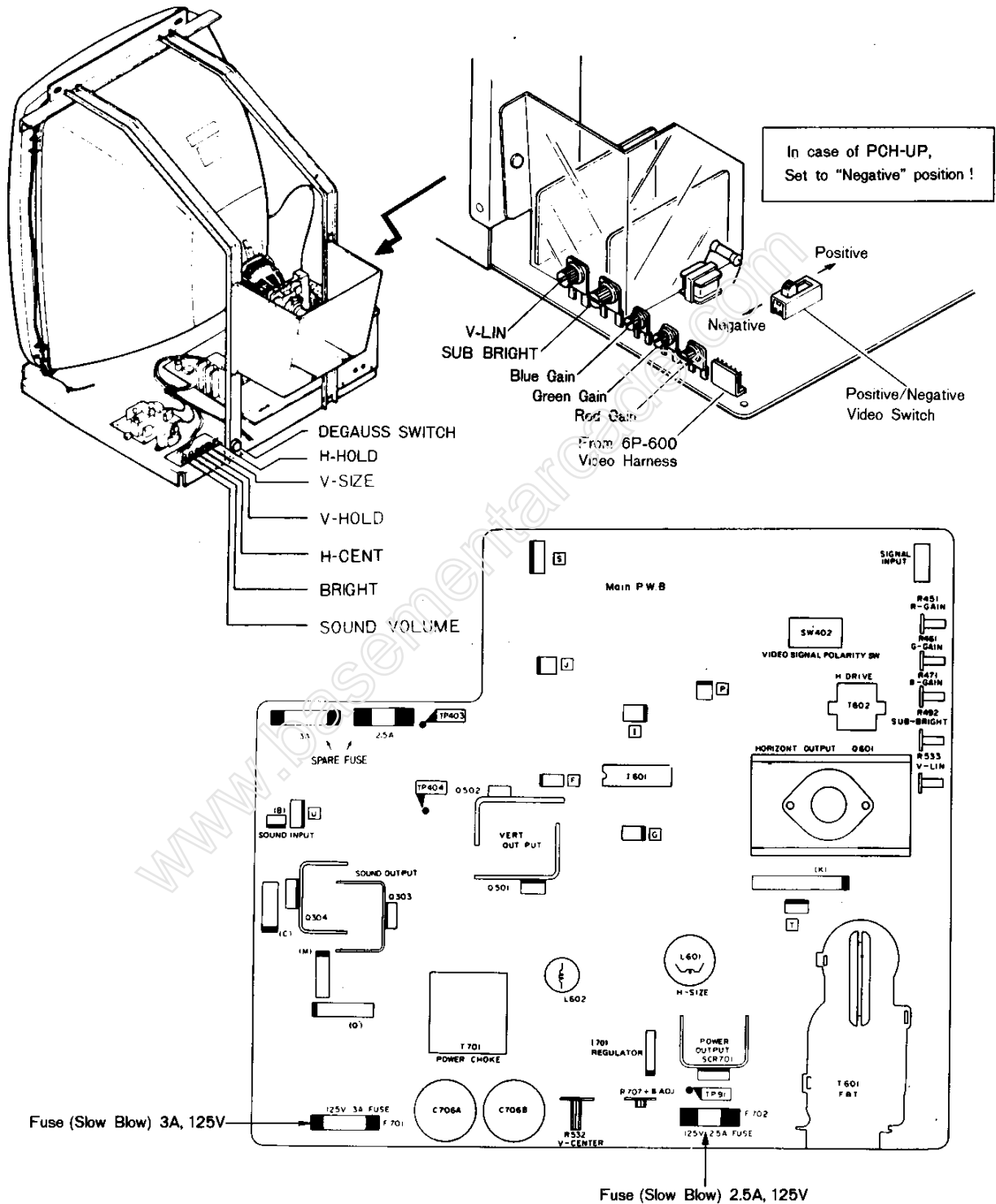

Fig. 6 Video Monitor : [Y51 Type] XM-2001N

WARNING

Do not touch the inside of the Video Monitor.
It contains many parts supplied with high voltage.

2. Option Switch Settings

A pair of Option Toggle Switches are mounted on the Game PCB.

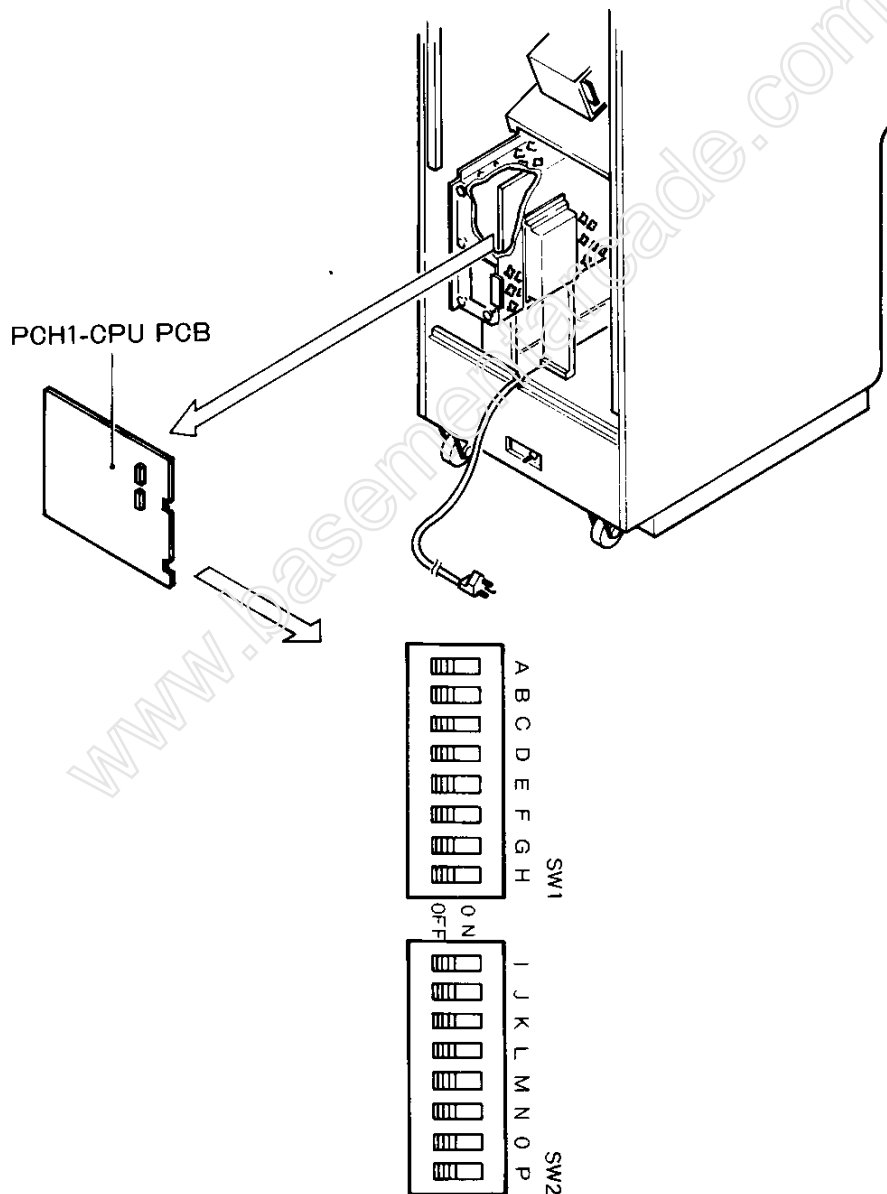

Fig. 7 Option Toggle Switches

A. Game Settings

WARNING

All the Option Switch Settings MUST be done with Power Off.

Fig. 8 Game Settings

		SW1 Toggle Settings		
		G	H	
Attract music	O N	O N		*
	OFF	OFF		
Self-Test/Game				
Game			OFF	*
Self-Test			O N	

* Factory Settings

STANDARD TIME (no bonus)

No Prime Time

SW1	Toggle Settings					
	A	B	C	D	E	F
Toggle A-Toggle F must be "OFF"	OFF	OFF	OFF	OFF	OFF	OFF

Seconds per Coin

SW2 Play Time/Coin	Toggle Settings							
	I	J	K	L	M	N	O	P
Free Play	OFF	OFF	OFF	OFF	OFF	OFF	OFF	O N
4 min. 50 sec.	OFF	O N	O N	O N	O N	O N	O N	O N
40 sec.	OFF	OFF	O N	O N	O N	O N	O N	O N
30 sec.	OFF	O N	OFF	O N	O N	O N	O N	O N
20 sec.	OFF	OFF	OFF	O N	O N	O N	O N	O N
10 sec.	OFF	O N	O N	OFF	O N	O N	O N	O N
4 min.	OFF	OFF	O N	OFF	O N	O N	O N	O N
3 min. 50 sec.	OFF	O N	OFF	OFF	O N	O N	O N	O N
40 sec.	OFF	OFF	OFF	OFF	O N	O N	O N	O N
30 sec.	OFF	O N	O N	O N	OFF	O N	O N	O N
20 sec.	OFF	OFF	O N	O N	OFF	O N	O N	O N
10 sec.	OFF	O N	OFF	O N	OFF	O N	O N	O N
3 min.	OFF	OFF	OFF	O N	OFF	O N	O N	O N
2 min. 50 sec.	OFF	O N	O N	OFF	OFF	O N	O N	O N
40 sec.	OFF	OFF	O N	OFF	OFF	O N	O N	O N
30 sec.	OFF	O N	OFF	OFF	OFF	O N	O N	O N
20 sec.	OFF	OFF	OFF	OFF	OFF	O N	O N	O N
10 sec.	OFF	O N	O N	O N	O N	OFF	O N	O N
2 min.	OFF	OFF	O N	O N	O N	OFF	O N	O N

PRIME TIME (bonus) for 2 COINS

When using PRIME TIME (bonus) for 2 COINS, both SW1 and SW2 must be adjusted for proper game operation

Prime Time bonus %

SW1	PRIME TIME BONUS %	TOTAL PRIME TIME = XXXX	Toggle Settings					
			A	B	C	D	E	F
Displayed on Video Monitor as follows : <div style="border: 1px solid black; padding: 5px; width: fit-content;"> Regular Time 1 COIN = 300 PRIME TIME 2 COINS = 600^{XXXX} </div>	8%	650	O N	O N	O N	OFF	OFF	OFF
	17%	700	OFF	OFF	OFF	O N	OFF	OFF
	25%	750	O N	OFF	OFF	O N	OFF	OFF
	33%	800	OFF	OFF	OFF	OFF	O N	OFF
	42%	850	O N	OFF	OFF	OFF	O N	OFF
	50%	900	OFF	O N	OFF	OFF	O N	OFF
	58%	950	O N	O N	OFF	OFF	O N	OFF
	67%	1000	OFF	OFF	O N	OFF	O N	OFF
	75%	1050	O N	OFF	O N	OFF	O N	OFF
	83%	1100	OFF	O N	O N	OFF	O N	OFF
	92%	1150	O N	O N	O N	OFF	O N	OFF
	100%	1200	OFF	OFF	OFF	O N	O N	OFF

EXAMPLE. Displayed as

Regular Time 1 COIN = 300(3min)
700(7min.)
PRIME TIME 2 COINS = 600(6min.)

Toggle A = OFF, B = OFF, C = OFF, D = ON, E = OFF, F = OFF,
 I = OFF, J = OFF, K = OFF, L = ON, M = OFF, N = ON, O = OFF, P = ON

Seconds per Coin

SW2 Play Time/Coin (sec)	Toggle Settings							
	I	J	K	L	M	N	O	P
4 min. (240)	OFF	OFF	O N	OFF	O N	O N	OFF	O N
3 min. 50 sec. (230)	OFF	O N	OFF	OFF	O N	O N	OFF	O N
40 sec. (220)	OFF	OFF	OFF	OFF	O N	O N	OFF	O N
30 sec. (210)	OFF	O N	O N	O N	OFF	O N	OFF	O N
20 sec. (200)	OFF	OFF	O N	O N	OFF	O N	OFF	O N
10 sec. (190)	OFF	O N	OFF	O N	OFF	O N	OFF	O N
3 min. (180)	OFF	OFF	OFF	O N	OFF	O N	OFF	O N
2 min. 50 sec. (170)	OFF	O N	O N	OFF	OFF	O N	OFF	O N
40 sec. (160)	OFF	OFF	O N	OFF	OFF	O N	OFF	O N
30 sec. (150)	OFF	O N	OFF	OFF	OFF	O N	OFF	O N
20 sec. (140)	OFF	OFF	OFF	OFF	OFF	O N	OFF	O N
10 sec. (130)	OFF	O N	O N	O N	O N	OFF	OFF	O N
2 min. (120)	OFF	OFF	O N	O N	O N	OFF	OFF	O N

* Factory Settings

PRIME TIME (bonus) for 4 COINS

When using PRIME TIME (bonus) for 4 COINS, both SW1 and SW2 must be adjusted for proper game operation

Prime Time bonus %

SW1	PRIME TIME BONUS %	TOTAL PRIME TIME = XXXX	Toggle Settings					
			A	B	C	D	E	F
Displayed on Video Monitor as follows : <div style="border: 1px solid black; padding: 5px; width: fit-content;"> Regular Time 1 COIN = 300 PRIME TIME 4 COINS = 1200^{XXXX} </div>	8%	1300	OFF	OFF	O N	OFF	OFF	OFF
	17%	1400	O N	OFF	O N	OFF	OFF	OFF
	25%	1500	OFF	O N	O N	OFF	OFF	OFF
	33%	1600	O N	O N	O N	OFF	OFF	OFF
	42%	1700	OFF	OFF	OFF	O N	OFF	OFF
	50%	1800	O N	OFF	OFF	O N	OFF	OFF
	58%	1900	OFF	OFF	OFF	OFF	O N	OFF
	67%	2000	O N	OFF	OFF	OFF	O N	OFF
	75%	2100	OFF	O N	OFF	OFF	O N	OFF
	83%	2200	O N	O N	OFF	OFF	O N	OFF
	92%	2300	OFF	OFF	O N	OFF	O N	OFF
	100%	2400	O N	OFF	O N	OFF	O N	OFF

EXAMPLE. Displayed as

Regular Time 1 COIN = 300(3min.)
 1500(15min.)
 PRIME TIME 4 COINS = ~~1200(12min.)~~

Toggle A = OFF, B = ON, C = ON, D = OFF, E = OFF, F = OFF,

I = OFF, J = OFF, K = OFF, L = ON, M = OFF, N = ON, O = OFF, P = OFF

Seconds per Coin

SW2 Play Time/Coin (sec)	Toggle Settings							
	I	J	K	L	M	N	O	P
4 min. (240)	OFF	OFF	O N	OFF	O N	O N	OFF	OFF
3 min. 50 sec. (230)	OFF	O N	OFF	OFF	O N	O N	OFF	OFF
40 sec. (220)	OFF	OFF	OFF	OFF	O N	O N	OFF	OFF
30 sec. (210)	OFF	O N	O N	O N	OFF	O N	OFF	OFF
20 sec. (200)	OFF	OFF	O N	O N	OFF	O N	OFF	OFF
10 sec. (190)	OFF	O N	OFF	O N	OFF	O N	OFF	OFF
3 min. (180)	OFF	OFF	OFF	O N	OFF	O N	OFF	OFF
2 min. 50 sec. (170)	OFF	O N	O N	OFF	OFF	O N	OFF	OFF
40 sec. (160)	OFF	OFF	O N	OFF	OFF	O N	OFF	OFF
30 sec. (150)	OFF	O N	OFF	OFF	OFF	O N	OFF	OFF
20 sec. (140)	OFF	OFF	OFF	OFF	OFF	O N	OFF	OFF
10 sec. (130)	OFF	O N	O N	O N	O N	OFF	OFF	OFF
2 min. (120)	OFF	OFF	O N	O N	O N	OFF	OFF	OFF

3. Self-Test and Bookkeeping

(1) Entry

There are three ways to enter Self-Test and Bookkeeping modes.

- (a) Press the Service Switch and Enter Button simultaneously during Attract Mode or Game Mode.
- (b) Start with game in Off position. While pressing the Service Switch, set the Power On/Off Switch to the "On" position. Through this entry, you have an option to reset the Bookkeeping RAM. Follow the instruction on the Video Monitor.
- (c) Start with game in Off position. Set Toggle H (SW1) on the Game PCB to on position. And set the Power On/Off Switch to the "On" position.

(2) Self-Test and Bookkeeping are self-explanatory on the Video Monitor as follows.

Fig. 9 Self-Test and Bookkeeping

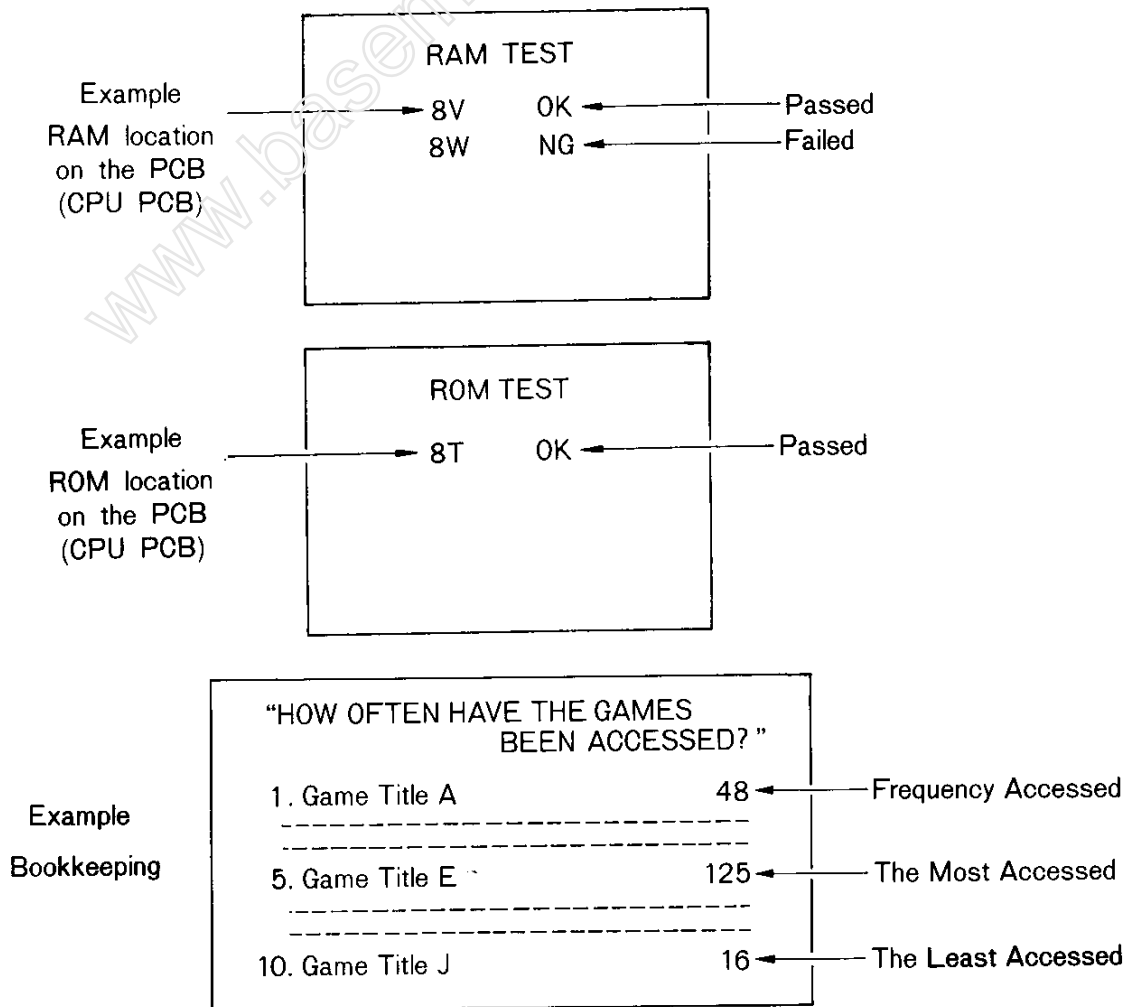

4. Maintenance and Repair

A. Fuse Replacement

This game contains 4 fuses. Replace fuses only with the same type as listed below.

Fig. 10 Specification of Fuses

(1) Main Fuse	U.S. : 5A 125V (90~120V) Europe : 3A 250V (200~240V) See Fig. 1 and 3
(2) Power Supply Fuse	3A 125V (Midget) See Fig. 3
(3) Video Monitor Fuses	
(a) [32 Type] 20-EZV(R-C)	} 4A 125V(Slow Blow) 0.3A 125V(Midget)
(b) [33 Type] 20-EZV(R-C)	
(c) [35 Type] 20-Z2AW	} See Fig. 5
(d) [Y51 Type] XM-2001N	2.5A 125V(Slow Blow) 3A 125V(Slow Blow) See Fig. 6

B. Cleaning

The exterior of the game, all metal parts and all plastic parts can be cleaned with a nonabrasive cleanser. You should be careful when cleaning the glass or plastic parts. A dry cloth may cause scratches which will result in a foggy appearance.

C. Operation Panel

(1) Operation Panel Removal

Before repairing or replacing any switches or A8 Control Lever Assembly on the Operation Panel, unplug the game. Open the Service Door, which are reach through the opening, and unlock the Clamps, located at each end on the underside of the Operation Panel. See Fig. 13.

(2) Micro-switch Replacement

Whenever you replace any micro-switch on the Operation Panel, a switch gap adjustment is needed as shown in Fig. 11. Also, see Fig. 19 for layout of Control Panel Switches.

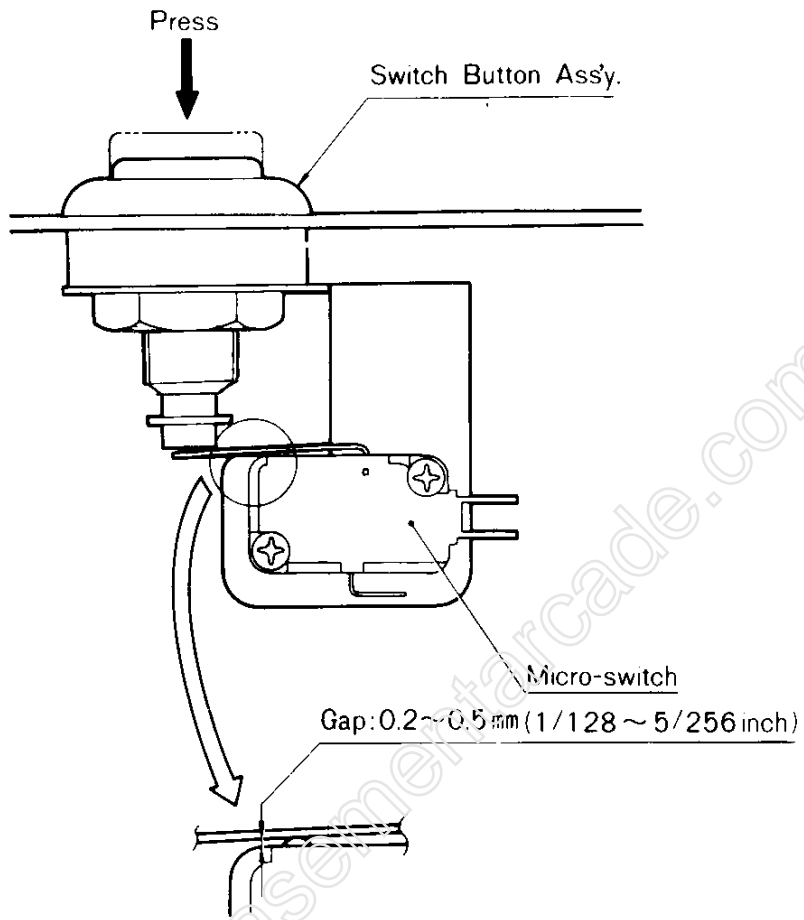

Fig. 11 Switch gap adjustment

(3) Lubrication for A8 Control Lever Assembly

To maintain the A8 Control Lever Assembly in good condition, lubricate the pillow balls and 8 way Guide Plate approx. every 3 months. See Fig. 12.

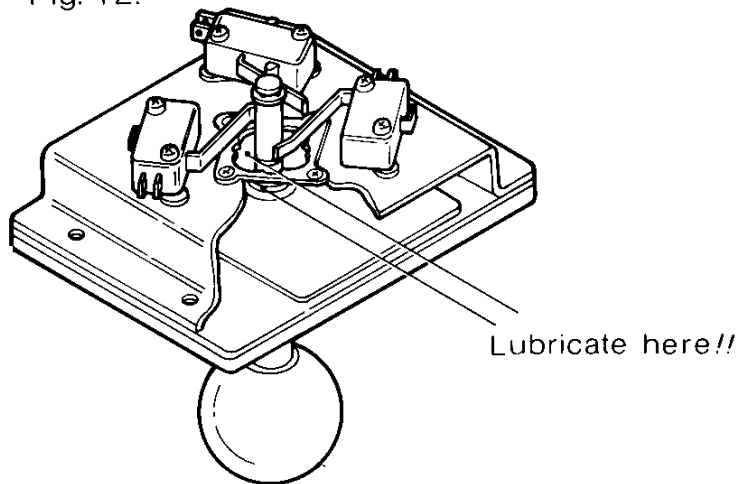

Fig. 12 Lubrication points

D. Video Monitor Removal

(1) Front Screen Removal

First remove the Operation Panel and then pull the Front Screen toward you.

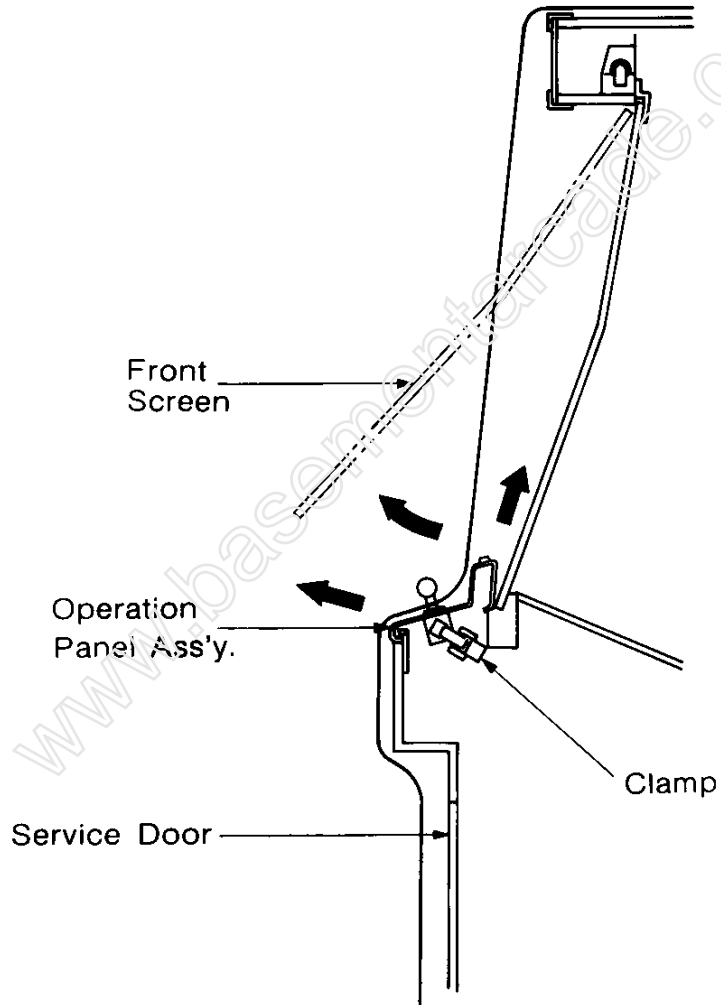

Fig. 13 Front Screen and
Operation Panel Ass'y. Removal

(2) Video Monitor Removal

If you need to remove the Video Monitor, follow the instructions listed below. But the following procedure should only be performed by an experienced service technician.

WARNING

It is recommended the game be left unplugged for at least one hour before removing the Video Monitor. This will probably discharge the CRT, but extreme caution is still necessary.

- (a) Make sure game is unplugged !!
- (b) Open the Rear Door Panel and remove the Front Screen.
- (c) Unplug all the harnesses and cables from the Video Monitor.
- (d) Standing at the front opening of the game, remove the four mounting bolts and flat washers. See Fig. 14.
- (e) Carefully lift the Video Monitor and pull toward you.

WARNING

Use extreme caution and do not touch electrical parts of the yoke area with your hands or with any metal object in your hands.

Remove the four mounting bolts and flat washers

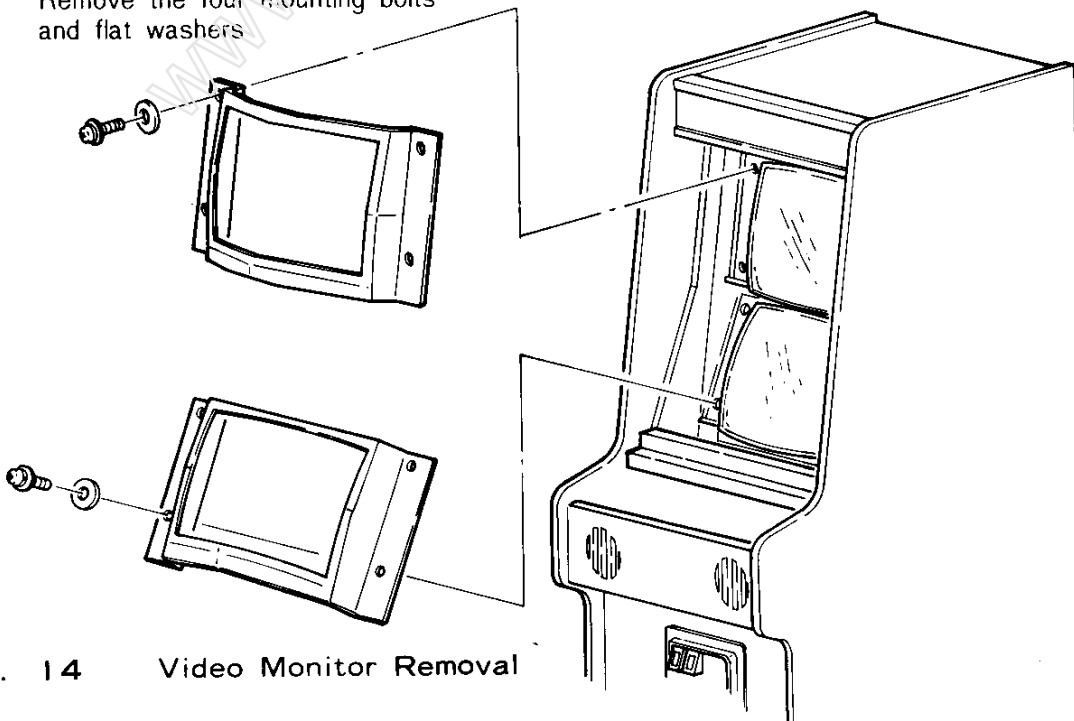

Fig. 14 Video Monitor Removal

E. Game PCB Removal and ROM PCB Exchange

- (a) Make sure the Power On/Off Switch is "Off" position!!
- (b) Open the Back Door.
- (c) Before removing Game PCB or exchanging ROM PCB, discharge your static electricity by touching Shield Cage with your hand.
- (d) Remove the 56-pin edge connector from the right side of the 054-FCC PCB on the 079 Shield Cover Ass'y.
- (e) Pull out 6 Fasteners located on perimeter of the 079 Shield Cover. See Fig. 15.
- (f) Remove the Game PCB from the Shield Cage by carefully sliding it straight out of the wooden slots in the Shield Cage.

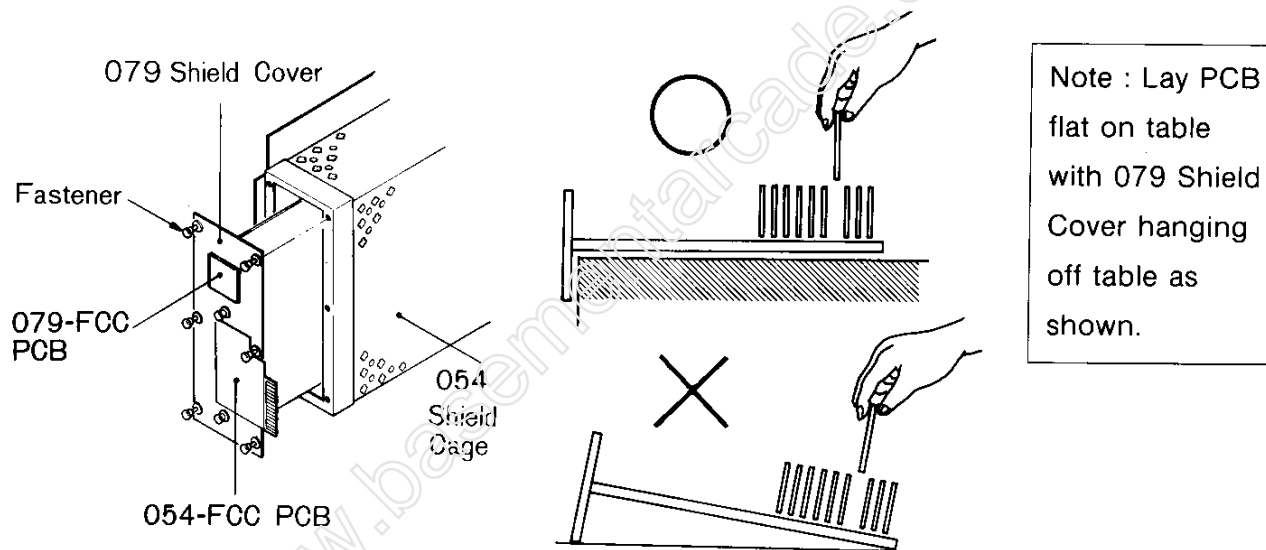

Fig. 15 Game PCB Removal and ROM PCB Exchange

WARNING

A reversed connector will damage your PCB!
If the connectors don't slip on easily, don't force them!

5. Radio Frequency Interference (RFI)

In order to protect against the RFI radiated from this equipment, please comply with the following.

- (a) Do not use non-Nintendo parts!
- (b) Do not modify your game circuitry!
- (c) Do not modify the wiring harness and connections!
- (d) Connect this game only to a grounded 3-wire outlet.
- (e) After servicing the Game PCB, shut the 079 Shield Cover completely with the Fasteners. See Fig. 15.

6. Wiring and Connection

Fig. 16 Wiring and Connection

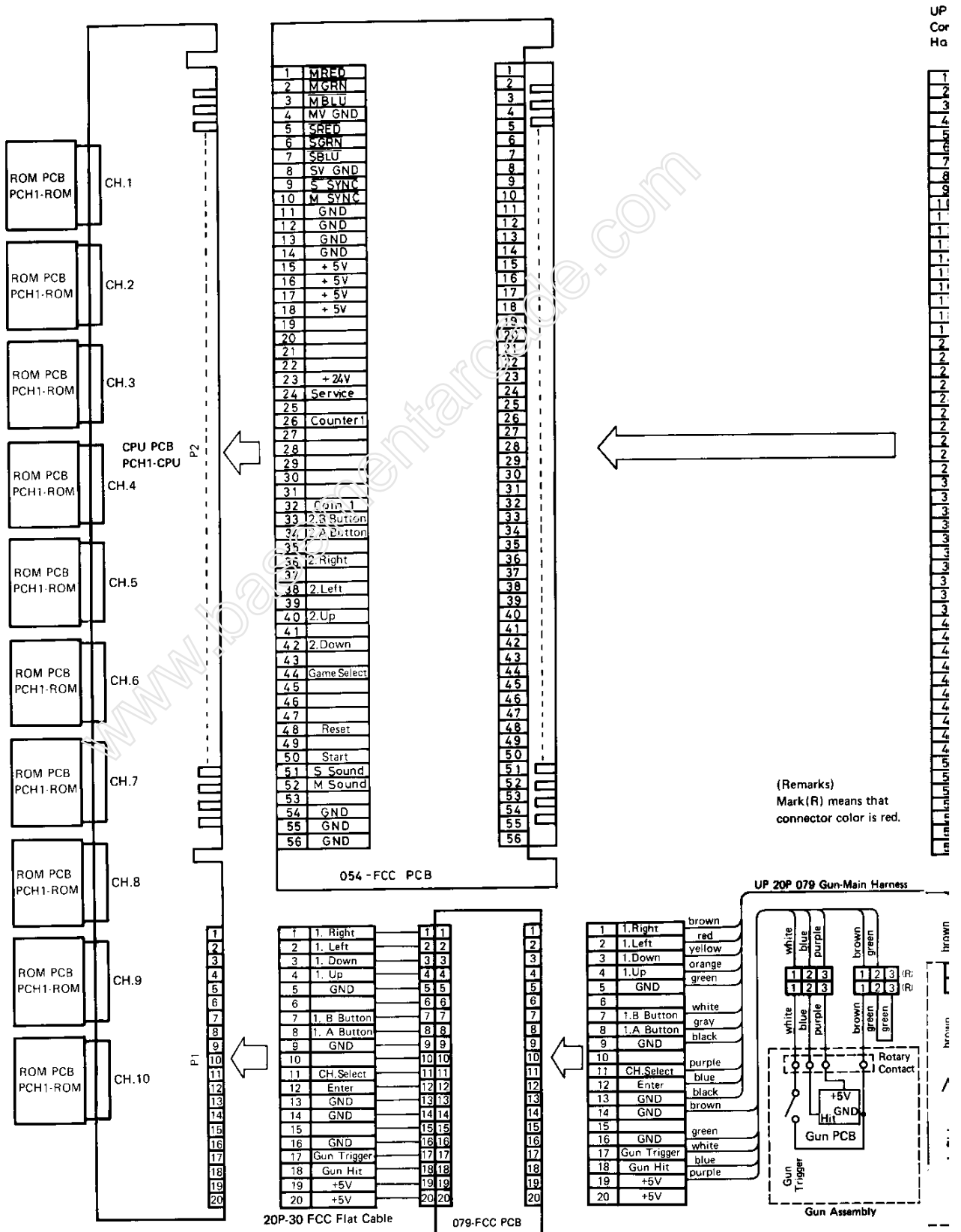

IP 56P 054 Edge
connecting
harness

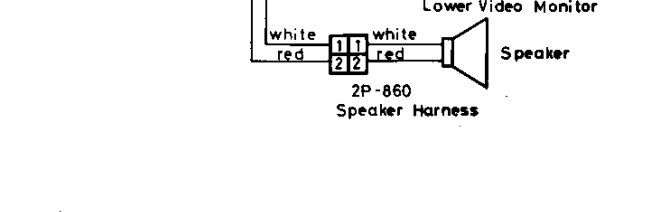
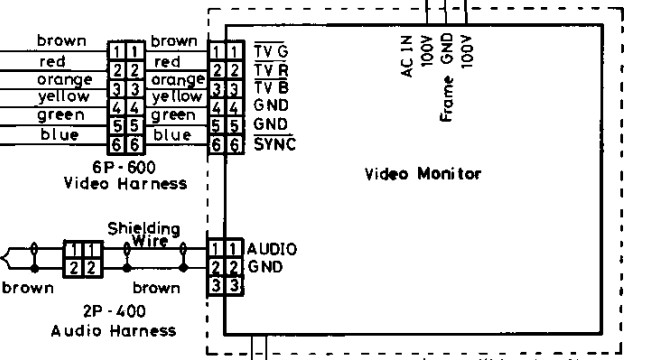
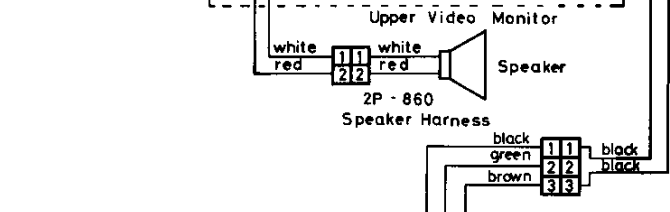
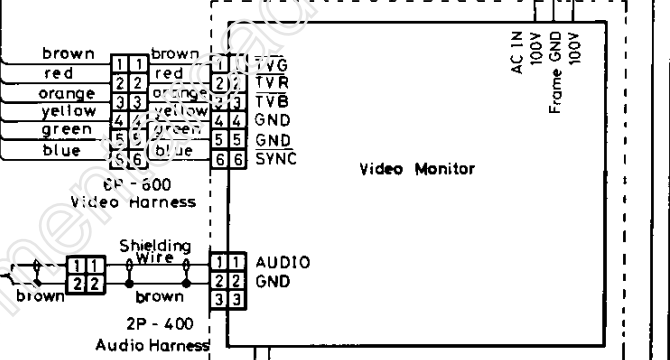
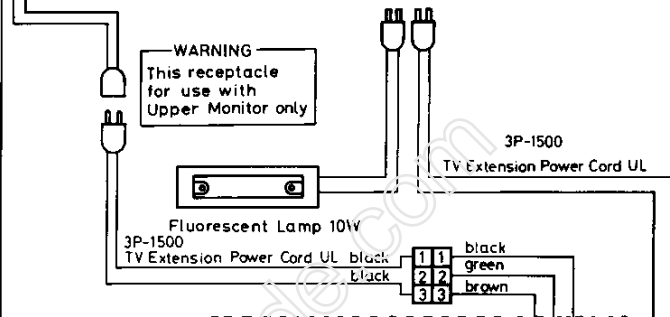
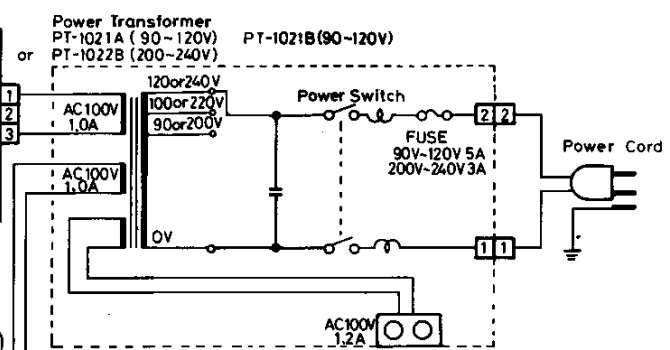
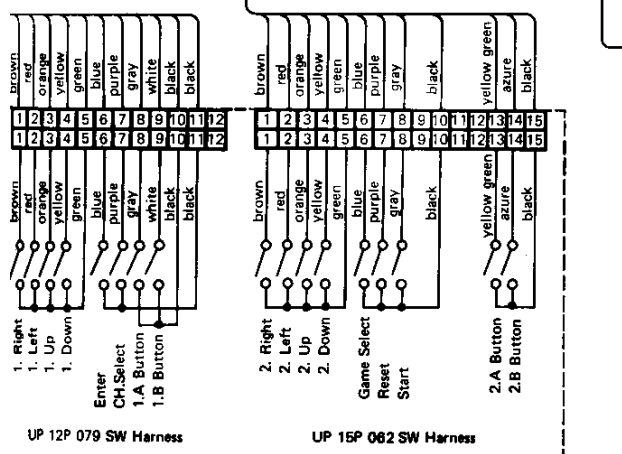
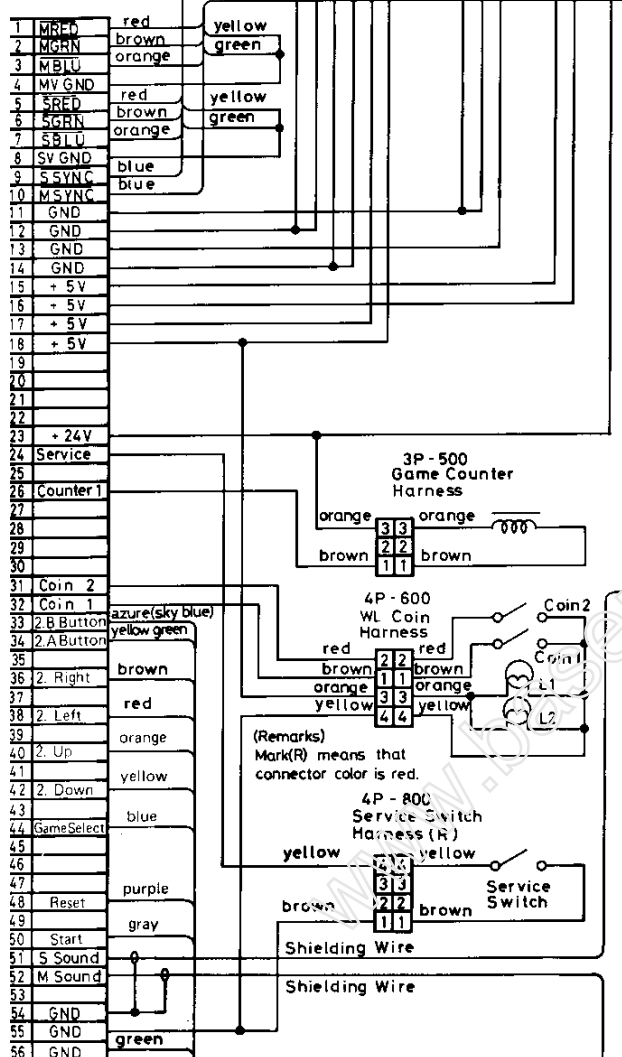

PCH Operation Panel

7. Parts Lists

A. PCH1-UP Game Cabinet Assembly

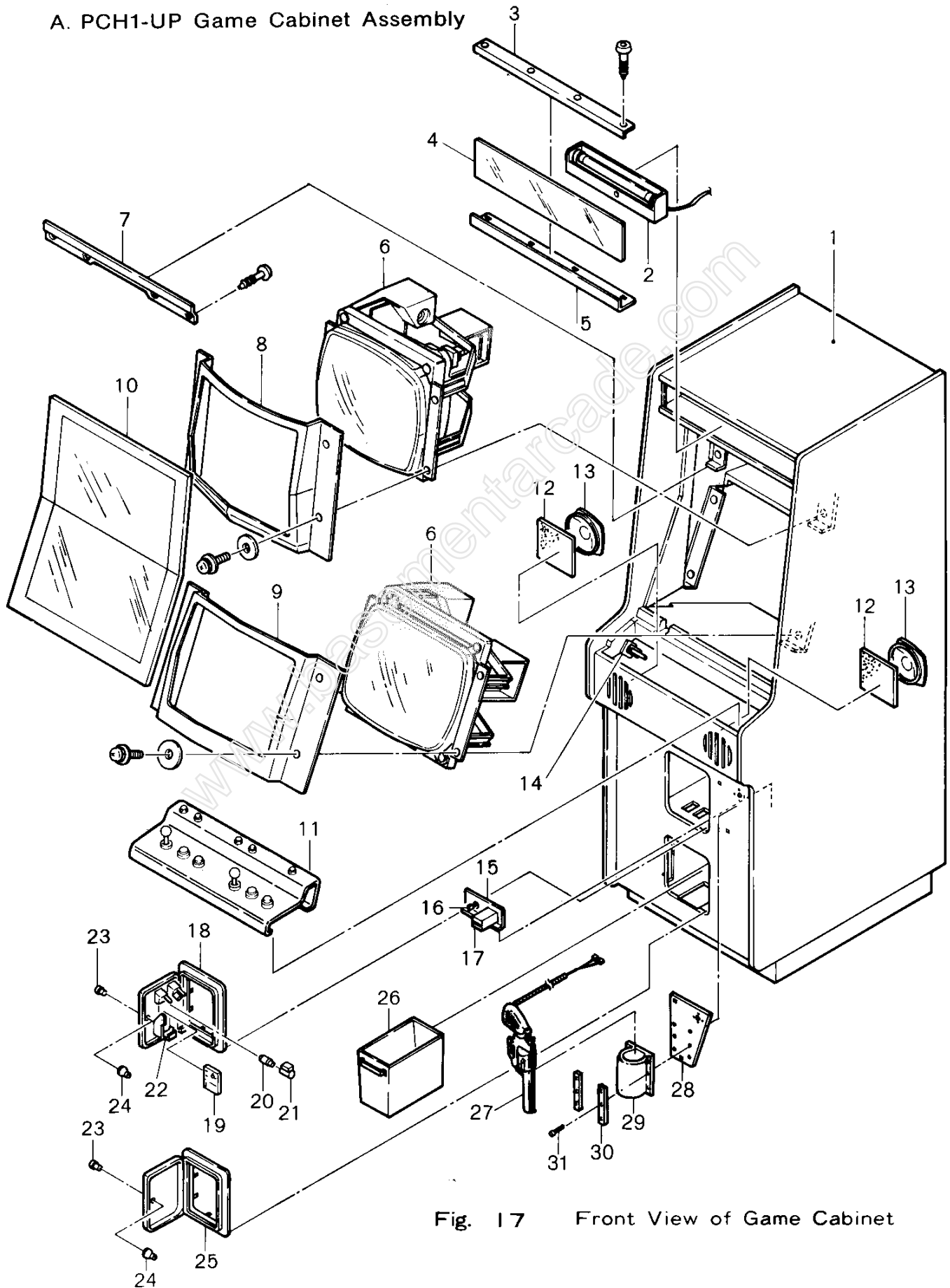

Fig. 17 Front View of Game Cabinet

A. PCH1-UP Game Cabinet Assembly : PARTS LIST

Continued

ITEM	PART No.	DESCRIPTION
1	CHPU-13-03	Body (Wooden Game Cabinet)
2	TKGU-01-29	Fluorescent Lamp Ass'y.
3	CHPU-11-19	Name Plate Retainer Upper 598L
4	PCHU-12-12	PCH Display Panel (Name Plate)
5	CHPU-11-11	Name Plate Retainer Lower 598L
6	TPPU-20-00	Video Monitor [32 Type] 20-EZV (R-C) Video Monitor [33 Type] 20-EZV (R-C) Video Monitor [35 Type] 20-Z2AW
6	MDSU-33-01	Video Monitor [Y51 Type] XM-2001N
7	CHPU-11-10	Front Screen Retainer 598L
8	CHPU-13-01	054 Black Cardboard Bezel Upper
9	CHPU-13-02	054 Black Cardboard Bezel Lower
10	CHPU-12-13	CHP-US Front Screen
11	PCHU-12-11	PCH Operation Panel (Panel Only)
12	TKGU-01-49	Speaker Grill (2 Required)
13	TKGU-01-43	Speaker (2 Required)
14	TKGU-01-31	Operation Panel Clamp A (2 Required)
15	TMAU-11-20	CS Plate 120W
16	TKGU-01-33	Service Switch (with Button)
17	TKGU-01-11	Game Counter
18	TMAU-14-17	Service Door ADD-S2: Order By Currency
19	TMAU-14-18	Coin Selector: Order By Currency
20	TMAU-34-17	Lamp BA-9S 6.3V 0.15A
21	TMAU-34-16	Lamp Socket BA-9S
22	TMAU-34-19	Micro-switch ADD D2MC-5F1
23	TMAU-14-12	Door Lock
24	TMAU-11-14	Cam B31R (2 Required)
25	TMAU-14-11	Cash Door ADD
26	TMAU-11-27	Cash Box ADD
27	MDSG2-02-01	062G2 Gun Assembly
28	PCHU-11-12	079 Gun Holster Base
29	MDSG2-12-19	Gun Holster
30	MDSG2-11-22	Gun Holster Plate
31	MDSG2-51-19	Button Bolt (6 Required)

A. PCH1-UP Game Cabinet Assembly

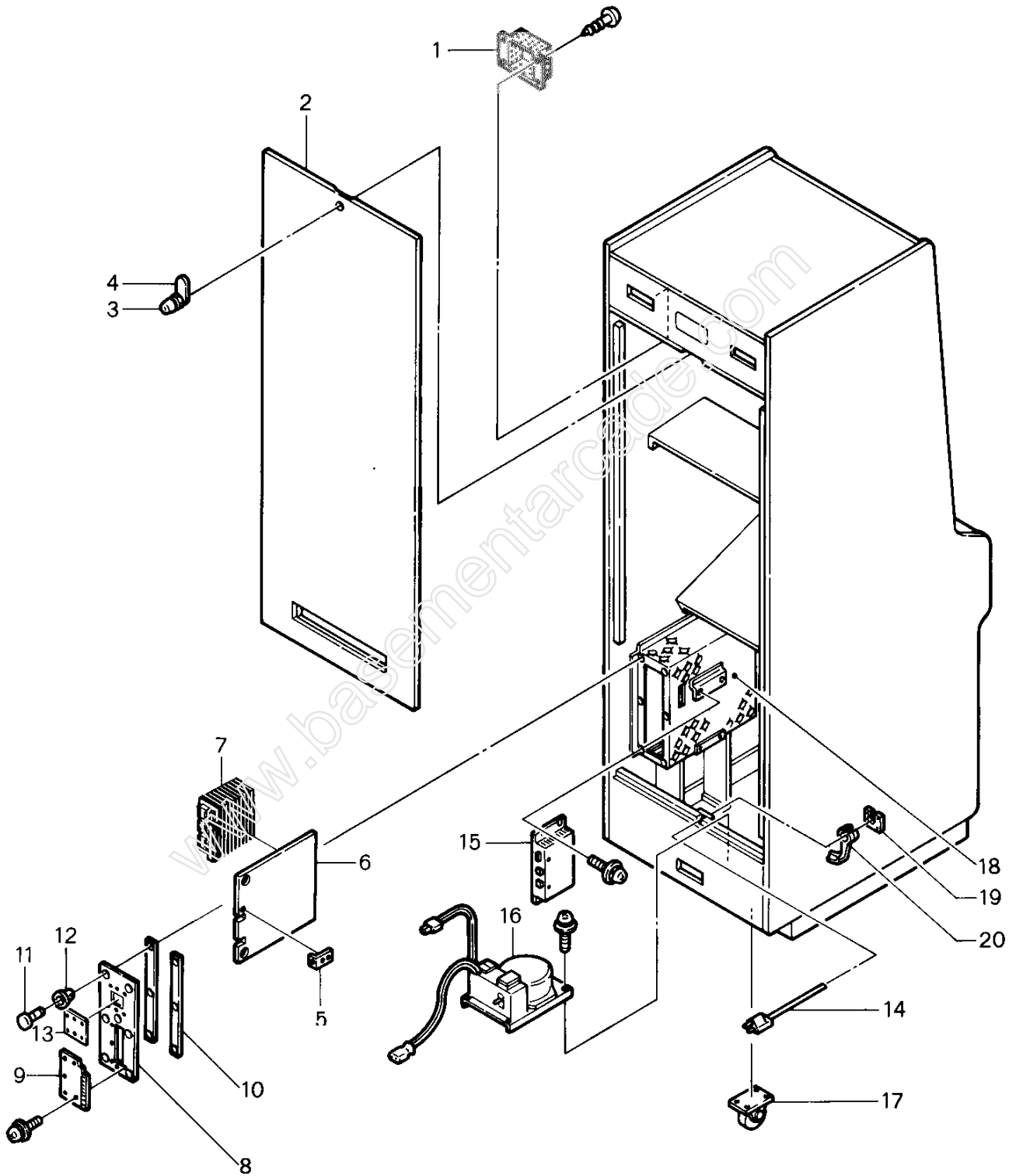

Fig. 18 Rear View of Game Cabinet

A. PCH1-UP Game Cabinet Assembly : PARTS LIST

ITEM	PART No.	DESCRIPTION
1	TKGU-01-61	Vent Grill (2 Required)
2	CHPU-13-15	Back Door
3	TMAU-14-14	Lock K6510
4	TMAU-11-15	Cam A
5	CHPU-11-18	PCB Stopper (2 Required)
6	PCHU-21-01	PCH1-CPU Complete PCB Assembly
7	PCHU-24-01	PCH1-ROM Complete PCB Assembly Order By Game Name
8	PCHU-11-11	079 Shield Cover
9	CHPU-23-01	054-FCC Complete PCB Assembly
10	CHPU-11-17	054 Shield Spacer (2 Required)
11	CHPU-23-35	Nylatch Fastener (8 Required)
12	CHPU-23-34	Nylatch Grommet (8 Required)
13	PCHU-23-01	079-FCC Complete PCB Assembly
14	TKGU-01-08	Power Cord: Order By Voltage & Plug Type
15	CHPU-88-01	PP-1000A Complete Power Supply Assembly
16	CHPU-08-01	PT-1021A Power Transformer (For 90~120V)
16	CHPU-18-01	PT-1021B Power Transformer (For 90~120V)
16	CHPU-18-02	PT-1022B Power Transformer (For 200~240V)
17	TKGU-01-30	Caster (2 Required)
18	CHPU-01-01-10	054 Shield Cage
19	TKGU-01-65	Strain Relief Bushing Plate
20	TKGU-01-10	Strain Relief Bushing

B. PCH1-UP Operation Panel Assembly

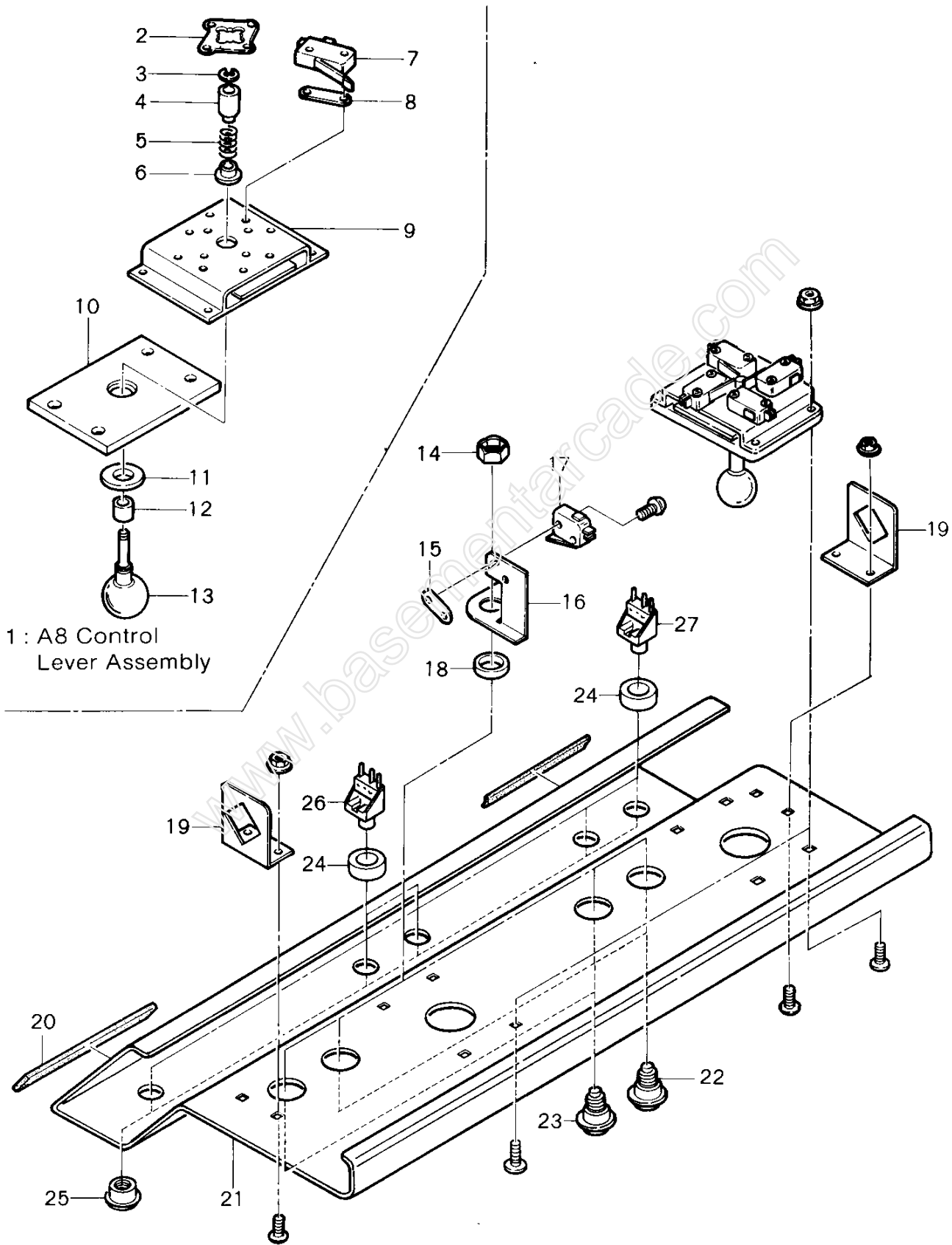

Fig. 19 Operation Panel Assembly

B. PCH1-UP Operation Panel Assembly : PARTS LIST

ITEM	PART No.	DESCRIPTION
1	MDST-14-12	A8 Control Lever Assembly
2	TNX-23-18	8 way Guide Plate
3	TKGU-23-23	E Ring 4
4	TKGU-23-21	Switch Collar
5	TKGU-23-22	Lever Spring
6	TKGU-23-20	Spring Stopper
7	TKGU-23-13	Micro-switch VL12L (Bent) (8 Required)
8	TKGU-23-17	Switch Spacer (8 Required)
9	TKGU-23-16	Bearing Bracket
10	TMAU-12-15	Lever Plate
11	TMAU-12-14	Control Knob Plate 28D
12	TMAU-12-16	Controller Knob Collar 8L
13	TMAU-11-18	Knob with Shaft 80.5L
14	TKGU-23-34	Pal Nut (4 Required)
15	TKGU-23-26	Nut Plate (4 Required)
16	TKGU-23-12	Switch Button Bracket (4 Required)
17	TMAU-34-18	Micro-switch VL12L (Straight)
18	TMAU-12-18	Collar 34×23×7H (4 Required)
19	TMAU-11-19	Operation Panel Fastener B 38W (2 Required)
20	CHPU-12-17	Black Sponge 2×20×590L
21	PCHU-12-11	PCH Operation Panel
22	MDSU-12-07	Button Assembly (Red) (2 Required)
23	MDST-12-21	Button Assembly (Black) (2 Required)
24	MDSA-23-29	Switch Collar (5 Required)
25	MDSA-23-30	Switch Bezel (5 Required)
26	MDSA-23-31	Switch P163C3RU Red (2 Required)
27	MDSA-23-32	Switch P163C3RU Black (3 Required)

C. PCH1-UP Wiring Harnesses

PART No.	DESCRIPTION	See Fig. 16
CHPU-41-16	UP 56P 054 Edge Connecting Harness	
TPPU-93-02	2P-400 Audio Harness (400mm) (2 Required)	
TPPU-93-07	6P-600 Video Harness (600mm) (2 Required)	
TMAU-41-12	3P-500 Game Counter Harness (500mm)	
CHPU-41-13	4P-800 Service Switch Harness (800mm)	
TMAU-41-14	4P-600 WL Coin Harness (600mm)	
TKGU-13-17	2P Speaker Harness [2P-860] (860mm) (2 Required)	
CHVU-41-11	3P-1500 TV Extension Power Cord UL (2 Required)	
MDSU-41-11	UP 15P 062 SW Harness	
PCHU-41-11	UP 12P 079 SW Harness	
PCHU-41-15	UP 20P 079 Gun-Main Harness	
PCHU-41-16	20P-30 FCC Flat Cable	

D. PCH1-CPU PCB Assembly : PARTS LIST

Continued

PART No.	DESCRIPTION (Reference Designations and Locations)
PCHU-21-01	PCH1-CPU Complete PCB Assembly
PCHU-21-11	Z80A Microprocessor (5X)
PCHU-21-12	RP2A03E Microprocessor (1H)
PCHU-21-13	RP2C03B PPU (3H)
PCHU-21-14	27128 16K-Byte EP-ROM 300ns PCH1-C-8T (8T)
PCHU-21-15	2764 8K-Byte EP-ROM 300ns PCH1-C-8K (8K)
PCHU-21-16	2764 8K-Byte EP-ROM 300ns PCH1-C-8M (8M)
PCHU-21-17	2764 8K-Byte EP-ROM 300ns PCH1-C-8P (8P)
PCHU-21-18	TMM2115BP-15 2K-Byte RAM 150ns (2K)
PCHU-21-19	HM6116 ASP-20 2K-Byte RAM 200ns (4K, 8R, 8V)
PCHU-21-20	TC5517 CPL-20 2K-Byte C-MOS RAM 200ns (8W)
PCHU-21-21	N82S129N 256×4-Bit Bipolar ROM PCH1-C-6D (6D)
PCHU-21-22	N82S129N 256×4-Bit Bipolar ROM PCH1-C-6E (6E)
PCHU-21-23	N82S129N 256×4-Bit Bipolar ROM PCH1-C-6F (6F)
PCHU-21-24	74LS00 Quad 2-Input NAND (8J, 6U)
PCHU-21-25	74LS02 Quad 2-Input NOR (4U)
PCHU-21-26	74LS04 Hex Inverters (8D, 3G, 8G, 5J, 7R, 7Y, 4Z)
PCHU-21-27	74LS08 Quad 2-Input AND (7X)
PCHU-21-28	74LS11 Triple 3-Input AND (5P)
PCHU-21-29	74LS14 Hex Schmitt Inverters (4V)
PCHU-21-30	74LS32 Quad 2-Input OR (8C, 5T)
PCHU-21-31	74LS42 4 To 10 Decoders (4T)
PCHU-21-32	74LS55 2-Wide 4-Input AND-OR-INVERT Gates (5K)
PCHU-21-33	74LS74A Dual "D" Flip-Flops (P, CL) (7J, 7K, 5M)
PCHU-21-34	74LS109A Dual J-K Flip-Flops (PLE, CL) (4Y)
PCHU-21-35	74LS139 Dual 2 To 4 Decoders (7H, 2L, 6T)
PCHU-21-36	74LS157 Quad 2 To 1 Data Selectors (7S, 7T, 7U, 7V)
PCHU-21-37	74LS161A 4-Bit Binary Counters (6H, 6J, 6K, 6L, 6M, 4R)
PCHU-21-38	74LS164 8-Bit Shift Registers (8H, 5Q)
PCHU-21-39	74LS165A 8-Bit Shift Registers (8A, 8B)
PCHU-21-40	74LS175 Quad "D" Flip-Flops (CL) (4S)
PCHU-21-41	74LS194A 4-Bit Shift Registers (6Q, 6R)
PCHU-21-42	74LS240 Octal Bus Inverters (TS) (7A, 7B, 7C)
PCHU-21-43	74LS244 Octal Buffers & Line Drivers (TS) (1L, 2M, 3M, 8S, 5V, 6V)
PCHU-21-44	74LS245 Octal Bus Transceivers (TS) (1K, 6Z)
PCHU-21-45	74LS259 8-Bit Addressable Latches (7D, 7E)
PCHU-21-46	74LS299 8-Bit Shift/Storage Registers (7L, 7N, 7Q)
PCHU-21-47	74LS367A Hex Bus Drivers (4L)
PCHU-21-48	74LS368A Hex Bus Drivers (8E, 8F, 5S)
PCHU-21-49	74HC373 Octal "D" Transparent Latches C-MOS (3K)
PCHU-21-50	74LS377 Octal "D" Flip-Flops (6P)
PCHU-21-51	74S04 Hex Inverters (2G, 6N)
PCHU-21-52	7437 Quad 2-Input NAND Buffers (4X)
PCHU-21-53	75471 Dual Peripheral AND Drivers (6C)
PCHU-21-54	74HC10 Triple 3-Input NAND C-MOS (8Y)
PCHU-21-55	PST518A Low Voltage Detector (7Z)
PCHU-21-56	LM324 Quad Operational Amplifiers (3E)
PCHU-21-57	LM3900 Quad Operational Amplifiers (1E)
PCHU-21-58	CD 4066 Quad Analog Switches C-MOS (3C, 2E)

PART No.	DESCRIPTION (Reference Designations and Locations)
PCHU-21-59	2SA933 Silicon PNP Transistor (Q11, Q12, Q14, Q15, Q17, Q18)
PCHU-21-60	2SA1015 Silicon PNP Transistor (Q3, Q5, Q7, Q20)
PCHU-21-61	2SC1740 Silicon NPN Transistor (Q8~Q10, Q13, Q16, Q19)
PCHU-21-62	2SC1815 Silicon NPN Transistor (Q1, Q2, Q4, Q6)
PCHU-21-63	ES1F Diode (D1)
PCHU-21-64	1S5277B Diode (D3, D4)
PCHU-21-65	EG01Y Diode (D2)
PCHU-21-66	DAN401 Quad Cathode-Common Diode Array (DA1~DA6)
PCHU-21-67	1.0f 5.5V Electric Double Layer Capacitor (EEC F5R5U105) (C3)
PCHU-21-68	68pf 50V Ceramic-Disc Capacitor (C44)
PCHU-21-69	100pf 50V Ceramic-Disc Capacitor (C35, C36, C45)
PCHU-21-70	180pf 50V Ceramic-Disc Capacitor (C11, C39)
PCHU-21-71	330pf 50V Ceramic-Disc Capacitor (C2, C6, C12, C40, C41)
PCHU-21-72	1000pf 50V Ceramic-Disc Capacitor (C5)
PCHU-21-73	0.01uf 50V Ceramic-Disc Capacitor (C4, C22, C38, C43, C80~C179)
PCHU-21-74	0.047uf 50V Ceramic-Disc Capacitor (C15~C17)
PCHU-21-75	0.2uf 12V Ceramic-Disc Capacitor (C21)
PCHU-21-76	0.047uf 50V Film Capacitor (C33, C34)
PCHU-21-77	1uf 16V Al Electrolytic Radial Cap. (C7, C8)
PCHU-21-78	3.3uf 16V Al Electrolytic Radial Cap. (C13, C14, C25, C28, C31, C32)
PCHU-21-79	10uf 16V Al Electrolytic Radial Cap. (C23, C24, C26, C27, C29, C30, C37, C42)
PCHU-21-80	33uf 16V Al Electrolytic Axial Cap. (C9, C10)
PCHU-21-81	47 μ f 16V Al Electrolytic Radial Cap. (C47~C50)
PCHU-21-82	100uf 16V Al Electrolytic Axial Cap. (C18, C46)
PCHU-21-83	100uf 25V Al Electrolytic Axial Cap. (C19)
PCHU-21-84	220uf 16V Al Electrolytic Axial Cap. (C1)
PCHU-21-85	470uf 16V Al Electrolytic Axial Cap. (C20)
PCHU-21-86	3.3 μ f 16V Tantalum Electrolytic Cap. (C85, C90, C93, C102, C109, C121, C127, C145, C157)
PCHU-21-87	0 Ohm Shunt Lead (R99)
PCHU-21-88	10 Ohm 1/4W \pm 5% Resistor (R7)
PCHU-21-89	33 Ohm 1/4W \pm 5% Resistor (R32, R37, R47, R57, R67)
PCHU-21-90	51 Ohm 1/4W \pm 5% Resistor (R8, R19, R23, R27, R31)
PCHU-21-91	100 Ohm 1/4W \pm 5% Resistor (R17, R20, R24, R28, R68, R69, R73)
PCHU-21-92	110 Ohm 1/4W \pm 5% Resistor (R3)
PCHU-21-93	330 Ohm 1/4W \pm 5% Resistor (R13, R14, R18, R21, R22, R25, R26, R29, R30, R36, R90, R91, R97, R98)
PCHU-21-94	510 Ohm 1/4W \pm 5% Resistor (R46, R56, R66)
PCHU-21-95	820 Ohm 1/4W \pm 5% Resistor (R1, R2)
PCHU-21-96	1K Ohm 1/4W \pm 5% Resistor (R94~R96, R120~R131)
PCHU-21-97	2K Ohm 1/4W \pm 5% Resistor (R15)
PCHU-21-98	2.2K Ohm 1/4W \pm 5% Resistor (R35, R40, R42, R45, R50, R52, R55, R60, R62, R65)
PCHU-21-99	4.7K Ohm 1/4W \pm 5% Resistor (R43, R53, R63)

PART No.	DESCRIPTION (Reference Designations and Locations)
PCHU-21-100	5.1K Ohm 1/4W±5% Resistor (R4, R5, R88, R89)
PCHU-21-101	7.5K Ohm 1/4W±5% Resistor (R16).
PCHU-21-102	10K Ohm 1/4W±5% Resistor (R12, R34, R38, R41, R44, R51, R54, R61, R64, R74, R82, R83, R87, R92, R93)
PCHU-21-103	12K Ohm 1/4W±5% Resistor (R71)
PCHU-21-104	20K Ohm 1/4W±5% Resistor (R6, R39, R70, R72)
PCHU-21-105	100K Ohm 1/4W±5% Resistor (R33, R75)
PCHU-21-106	200K Ohm 1/4W±5% Resistor (R9~R11)
PCHU-21-107	360K Ohm 1/4W±5% Resistor (R79)
PCHU-21-108	750K Ohm 1/4W±5% Resistor (R78, R80, R84)
PCHU-21-109	1M Ohm 1/4W±5% Resistor (R76, R85)
PCHU-21-110	1.8M Ohm 1/4W±5% Resistor (R81)
PCHU-21-111	2.2M Ohm 1/4W±5% Resistor (R77, R86)
PCHU-21-112	Hex 5.1K Ohm Series Resistor Array (RM1, RM16)
PCHU-21-113	Octal 1K Ohm Series Resistor Array (RM5, RM8~RM10, RM13)
PCHU-21-114	Quad 68 Ohm Parallel Resistor Array (RM6, RM7, RM11, RM12, RM14, RM15)
PCHU-21-115	NT-01 Resistor Array (RM2~RM4)
PCHU-21-116	500 Ohm Variable Resistor. Red Cap (VR1)
PCHU-21-117	500 Ohm Variable Resistor. Green Cap (VR2)
PCHU-21-118	500 Ohm Variable Resistor. Blue Cap (VR3)
PCHU-21-119	8 MHz Crystal (X1)
PCHU-21-120	20.160MHz Crystal (X2)
PCHU-21-121	21.47727 MHz Crystal (X3)
PCHU-21-122	DC-DC Converter (Input 5V-Output 12V : MD12P070/150)
PCHU-21-123	8-Station, Single-Throw, DIP Bit Switch (SW1, SW2)
PCHU-21-124	MINI-BIT Header (SW3)
PCHU-21-125	16 Pin DIP IC Socket (S6~S8)
PCHU-21-126	28 Pin DIP IC Socket (S2~S5)
PCHU-21-127	40 Pin DIP IC Socket (S1, S9, S10)
PCHU-21-128	20 Pin Flat Cable Header (P1)
PCHU-21-129	96 Pin DIN Connector Receptacle (CH.1~CH.10)
PCHU-21-130	GL-3HD1 Visible Light Emitting Diode (LED1)

E. PCH1-ROM PCB Assembly : Order By Game Name

F. 054-FCC PCB Assembly : PARTS LIST

PART No.	DESCRIPTION (Reference Designations)
CHPU-23-01	054-FCC Complete PCB Assembly
CHPU-23-11	252-28-50-168 56P Edge Connector
CHPU-23-12	330 pf 50V Ceramic-Disc Capacitor (C1~C30)
CHPU-23-13	Ferrite Beads BL 02RN2-R62 (FC1~FC30)

G. 079-FCC PCB Assembly : PARTS LIST

PART No.	DESCRIPTION (Reference Designations)
PCHU-23-01	079-FCC Complete PCB Assembly
PCHU-21-128	20 Pin Flat Cable Header (P1, P2)
CHPU-23-12	330 pf 50V Ceramic-Disc Capacitor (C1~C19)
CHPU-23-13	Ferrite Beads BL 02RN2-R62 (FB1~FB19)

H. PP-1000A Power Supply Assembly : PARTS LIST Continued

PART No.	DESCRIPTION (Reference Designations)
CHPU-88-01	PP-1000A Complete Power Supply Assembly
CHPU-88-02	3D-0163 Complete Power Supply PCB Assembly
CHPU-88-11	3D-3000 Hybrid IC (IC1)
CHPU-88-12	uPC78M24 3-Terminal Regulator (IC2)
CHPU-88-13	TL431CLP Adjustable Shunt Regulator (IC3)
CHPU-88-14	TLP541G Photo Coupler (PC1)
CHPU-88-15	PC614 Photo Coupler (PC2)
CHPU-88-16	RB404/S4VB40 Diode (D1)
CHPU-88-17	C25P04Q/20CS04M Diode (D12)
CHPU-88-18	30DF2 Diode (D11)
CHPU-88-19	1S1835/10DF6 Diode (D6, D7, D10, D14)
CHPU-88-20	1S954 Diode (D3)
CHPU-88-21	RD5. 1EB3 Zener Diode (ZD1)
CHPU-88-22	5P2M Thyristor (Q1)
CHPU-88-23	2SC2562 Silicon NPN Transistor (Q2)
CHPU-88-24	2SC2749 Silicon NPN Transistor (Q3)
CHPU-88-25	0.01 uf 50V Mylar Capacitor (C6, C9, C27)
CHPU-88-26	0.1 uf 50V Mylar Capacitor (C13)
CHPU-88-27	1000 pf 50V Mylar Capacitor (C12)
CHPU-88-28	0.047 uf 630V Metallized Film Cap. (C1, C4)
CHPU-88-29	0.22 uf 250V Metallized Film Cap. (C10, C28, C29)
CHPU-88-30	2200 pf 2KV Ceramic-Disc Capacitor (C2,C3,C11,C15,C18)
CHPU-88-31	4.7 uf 50V Al Electrolytic Cap. (C7)
CHPU-88-32	47 uf 35V Al Electrolytic Cap. (C8, C17)
CHPU-88-33	330 uf 200V Al Electrolytic Cap. (C5)
CHPU-88-34	1000 uf 50V Al Electrolytic Cap. (C16)
CHPU-88-35	3300 uf 10V Al Electrolytic Cap. (C19~C26)
CHPU-88-36	100 Ohm 1/4W $\pm 5\%$ Carbon Resistor (R9,R11,R12,R23,R24)
CHPU-88-37	1K Ohm 1/4W $\pm 5\%$ Carbon Resistor (R4, R6, R15)
CHPU-88-38	1.5K Ohm 1/4W $\pm 5\%$ Carbon Resistor (R25)
CHPU-88-39	2.4K Ohm 1/4W $\pm 5\%$ Carbon Resistor (R26)
CHPU-88-40	10K Ohm 1/4W $\pm 5\%$ Carbon Resistor (R7)
CHPU-88-41	24K Ohm 1/4W $\pm 5\%$ Carbon Resistor (R17)
CHPU-88-42	30K Ohm 1/4W $\pm 5\%$ Carbon Resistor (R8)
CHPU-88-43	5.1 Ohm 1/2W $\pm 5\%$ Carbon Resistor (R19, R21)

No.	DESCRIPTION (Reference Designations)		
CHPU-88-44	100	Ohm 1/2W \pm 5% Carbon Resistor	(R5)
CHPU-88-45	100K	Ohm 1/2W \pm 5% Carbon Resistor	(R3, R14)
CHPU-88-46	5.1	Ohm 5W \pm 5% Cement Resistor	(R1)
CHPU-88-47	20	Ohm 5W \pm 5% Cement Resistor	(R22)
CHPU-88-48	30	Ohm 5W \pm 5% Cement Resistor	(R10)
CHPU-88-49	100	Ohm 5W \pm 5% Cement Resistor	(R16)
CHPU-88-50	510	Ohm 5W \pm 5% Cement Resistor	(R20)
CHPU-88-51	2K	Ohm Vertical Cermet Trimpot	(VR2)
CHPU-88-52	50K	Ohm Vertical Cermet Trimpot	(VR1)
CHPU-88-53	El-40	Type 3D-0163 Switching Transformer	(TR)
CHPU-88-54	SC2A	Choke Coil	(L1)
CHPU-88-55	SF-C27-00105-01	Choke Coil	(L2)
CHPU-88-56	3A FGMB NR	Type Fuse	
CHPU-88-57	OG751-0062	Fuse Holder (2 per assembly)	
CHPU-88-58	Heat Sink Clip	(3 per assembly)	
CHPU-88-59	Thermally Conductive Rubber		
CHPU-88-60	2-Pin AC Input Connector	Receptacle on PCB	
CHPU-88-61	6-Pin DC Output Connector	Receptacle on PCB	
CHPU-88-62	7-Pin DC Output Connector	Receptacle on PCB	
CHPU-88-65	3D-0163-32	Type Heat Sink	
CHPU-88-63	3D-0163-30	Type Metal Frame	
CHPU-88-64	3D-0163-31	Type Metal Cover	
CHPU-88-66	3-Pin AC Input Connector Ass'y.	on Metal Frame	
CHPU-88-67	9-Pin DC Output Connector Ass'y.	on Metal Frame	
CHPU-88-68	12-Pin DC Output Connector Ass'y.	on Metal Frame	
CHPU-88-69	Metal PCB Retainer	(4 per assembly)	

I. PCH1-UP Fuses

PART No.	DESCRIPTION(Reference Designations)		
TKGU-11-08	Main Fuse U.S.	5A 125V	
CHVU-63-11	Main Fuse Europe	3A 250V	
CHPU-88-56	Power Supply Fuse	3A 125V(Midget)	
TKGU-11-12	Video Monitor Fuse 20-EZV(R-C), 20-Z2AW	4A 125V(Slow Blow)	(F302)
TKGU-11-13	Video Monitor Fuse 20-EZV(R-C), 20-Z2AW	0.3A 125V(Midget)	(F301)
MDST-63-12	Video Monitor Fuse XM-2001N	2.5A 125V(Slow Blow)	(F702)
MDST-63-13	Video Monitor Fuse XM-2001N	3A 125V(Slow Blow)	(F701)

MEMO

www.basementarcade.com

www.basementarcade.com